

IMMOBILISATION SPIDER

Service repair no - 86.77.03

Remove

1. Remove LH front seat cushion.
2. Release retaining clip and remove battery access cover.
3. Slacken battery lead clamp bolts.
4. Turn starter switch 'on'.
5. Turn starter switch 'off' and remove key.
6. Disconnect battery leads.



NOTE: Operation 6 needs to be carried out within 15 seconds to avoid activating battery backed-up alarm sounder, if fitted.

7. Remove battery clamp and 'J' bolts.
8. Remove 4 nuts securing immobilisation spider housing box to fixing studs on front face of battery box.
9. Remove grommet securing spider harness to corner face of battery box.
10. Carefully pull harness into battery box, lift spider housing box and place on front edge of seat base.
11. Using a suitable sheet to protect inside of vehicle, grind heads off 6 monobolts securing lid to spider box housing.
12. Detach lid from housing and disconnect spider harness plug.
13. Unscrew two nuts and remove immobilisation spider from lid studs.



NOTE: If spider box lid and/or sealing gasket is damaged during operation 11 a new lid will need to be fitted.



NOTE: A new immobilisation spider must be initialised using TestBook.

Refit

14. Fit immobilisation spider onto lid studs and secure with retaining nuts.
15. Reconnect harness plug to spider and ensure it fully 'clicks' home.
16. Position lid and spider assembly into box housing so that harness plug is furst away from harness entry.

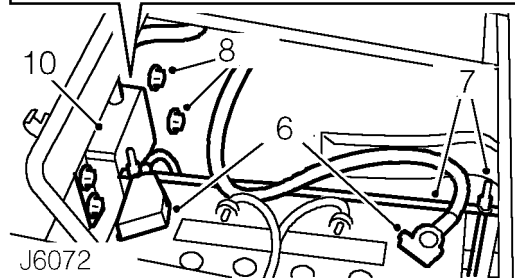
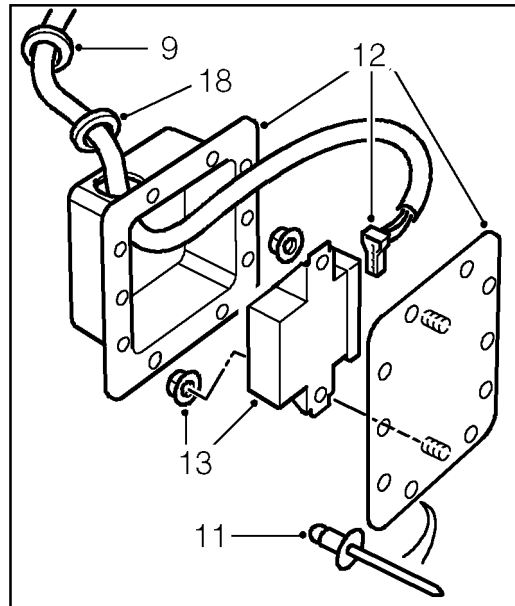

17. Secure lid to spider box housing with monobolts.
18. Refit harness grommet into spider box, if disturbed on removal procedures, and ensure harness covering is fully inserted through grommet to make water tight seal.
19. Push excess harness cable through corner face of battery box and fit grommet.
20. Fit spider housing box to fixing studs and secure with four nuts.
21. Fit 'J' bolts and clamp to secure battery,
22. Reconnect battery leads.
23. Fit battery access cover.
24. Fit LH seat cushion.
25. Test immobilisation and alarm system.