

8. Tighten centre main bearing cap bolts to 133 Nm. **Big-end bearings**

11. Remove seal guides LRT-12-035 and select feeler gauges to a thickness of 0.80 mm, position gauges on number 5 main bearing cap adjacent to oil seals.
12. Position a sharp blade on feeler gauges and keeping blade parallel to bearing cap, slice excess material off oil seal
13. Repeat above procedures for remaining seal.



CAUTION: Seals should be left to settle for as long as possible before they are trimmed.



3. Move numbers 1 and 4 connecting rods fully to one side of crankshaft journal and using feeler gauges, check end-float of both connecting rods on journals is between 0.15 and 0.35 mm.
4. If end-float is outside limits, replace connecting rod.
5. Check that crankshaft rotates smoothly.
6. Repeat above procedures for numbers 2 and 3 big-end bearings.



Crankshaft rear oil seal - refit

1. Ensure that oil seal running surface on crankshaft and oil seal housing mating surface on cylinder block are clean and oil free and that bolt holes in cylinder block are clean and dry.

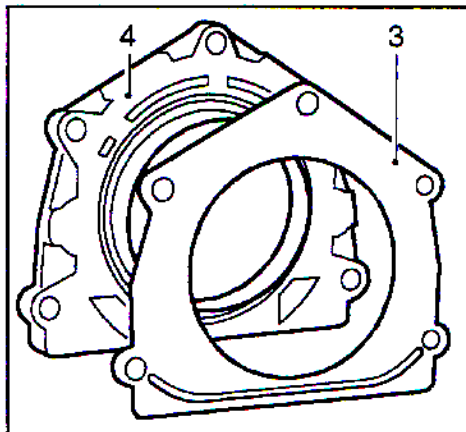
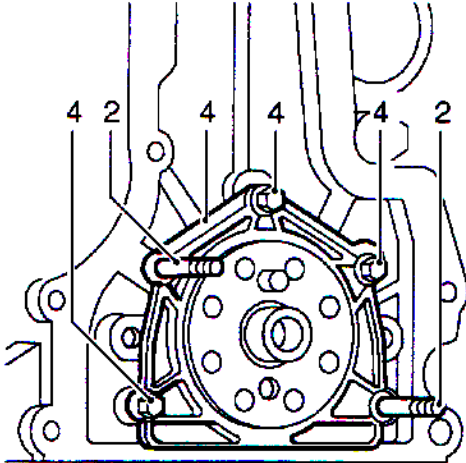

12M2949

2. Screw 2 slave guide studs into cylinder block.
3. Position new gasket to cylinder block ensuring that groove along bottom edge of gasket is towards block.



NOTE: 'O' ring fitted to early engines is no longer required.

4. Slide oil seal protector sleeve over crankshaft, fit oil seal and housing over guide studs and crankshaft, fit and finger tighten 3 bolts, recover oil seal protector sleeve.



CAUTION: Do not lubricate oil seal or running surface on crankshaft. Do not separate protector sleeve from oil seal and do not touch lip of seal. If protector sleeve is removed or seal is inadvertently handled, it must not be fitted as the coating applied to the oil seal during manufacture will be destroyed and oil leakage will result.

5. Remove 2 guide studs, fit and finger tighten remaining 2 bolts.
6. Tighten 5 bolts by diagonal selection to 25 Nm.