

OVERHAUL REAR AXLE DIFFERENTIAL ASSEMBLY (SALISBURY) LAND ROVER ONE TEN MODELS

Service tools:

- 47 screw press;
- 18G 131 C axle spreader or axle compressor GKN 131;
- 18G 191 dial gauge, bracket and base;
- 18G 1122 screw press;
- 18G 1205 spanner for drive coupling;
- S 123 A pinion bearing cup remover;
- 18G 47 BK pinion bearing cone remover/replacer;
- 18G 47 BL differential bearing remover;
- 18G 1122 G pinion bearing cup replacer;
- 18G 134 DP differential bearing replacer;
- 18G 191 P setting gauge for pinion height or 18G 191-4 universal setting block;
- 18G 131 F pegs for axle spreader;
- RO 1008 oil seal replacer

DISMANTLE

NOTE: All fixing bolts used on the differential assembly and differential cover have metric threads.

1. Drain off the differential lubricating oil, and refit plug.
2. Remove the rear axle assembly from the vehicle.
3. Remove the hub driving member fixings.
4. Withdraw the driving member and axle shaft sufficiently to disengage the differential.
5. Repeat instruction 4 for the other axle shaft.
6. Remove the fixings and support strip at the differential cover and withdraw the cover and joint washer.
7. Note the relationship marking on the bearing caps and axle casing to ensure correct refitting.

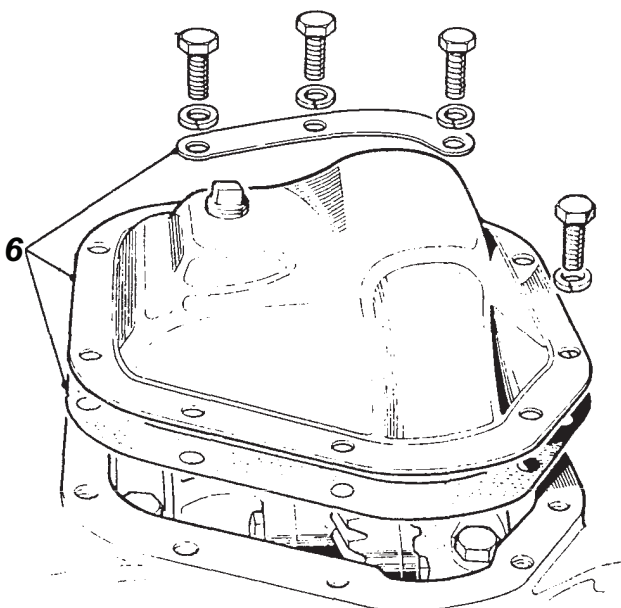

ST650M

8. Remove the fixings and withdraw the differential bearing caps.

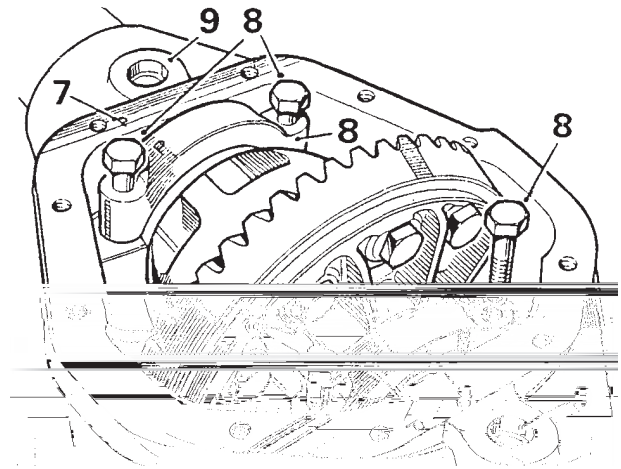

ST639M

Using axle spreader 18G 131 C

9. Clean out and examine the spreader tool pegholes provided in the gear casing face; ensure that the holes are free from dirt and burrs and damage.
10. Ensure that the turnbuckle adjuster is free to turn.
11. Fit the axle spreader to engage the peg holes. Spreader 18G 131 C, Adaptor pegs 18G 131 F.
12. Using a spanner, turn the adjuster until all free play between the spreader and casing is taken up, denoted by the adjuster becoming stiff to turn.
13. Check that the side members of the spreader are clear of the casing.
14. Stretch the casing, rotating the adjuster by one flat at a time, until the differential assembly can be levered out. Do not lever against the spreader; use suitable packing under the levers to avoid damage to the casing.

CAUTION: To prevent permanent damage to the gear carrier case, it must not be over-stretched. Each flat on the turnbuckle is numbered to enable a check to be made on the amount turned. The maximum stretch permitted is 0,30 mm (0.012 in), equivalent to three flats.

15. Ease off the adjuster and remove the spreader

continued

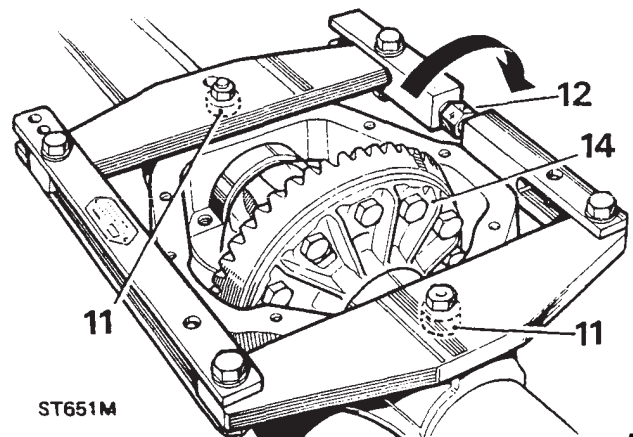

ST651M

Using axle compressor GKN 131

16. Place the tool on to the differential casing, as illustrated, with the weld seam uppermost. Ensure that the plates rest squarely on the differential machined surface and the end bars butt against the edges of the casing.
17. Tighten the adjusting nuts by hand only, until all slack is taken up.
18. Continue to tighten both nuts alternately with a spanner, one flat at a time, to a maximum of three flats.
19. Carefully lever-out the differential assembly.

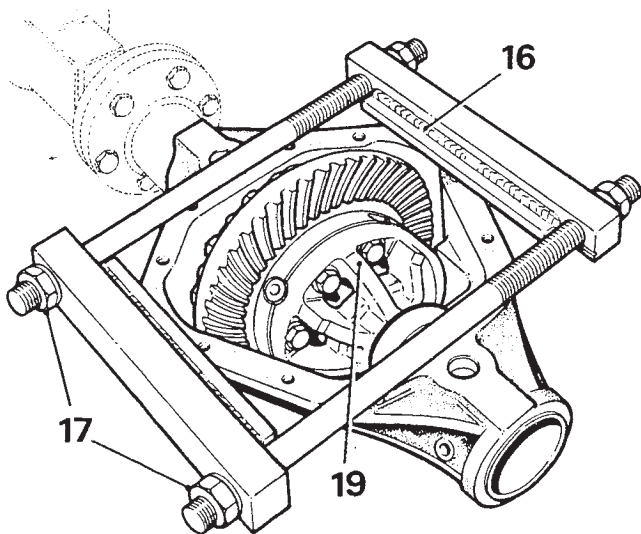

ST597M

Dismantle differential

20. Add alignment marks between the crown wheel and the differential case for reassembly purposes, then remove the fixings and withdraw the crown wheel.

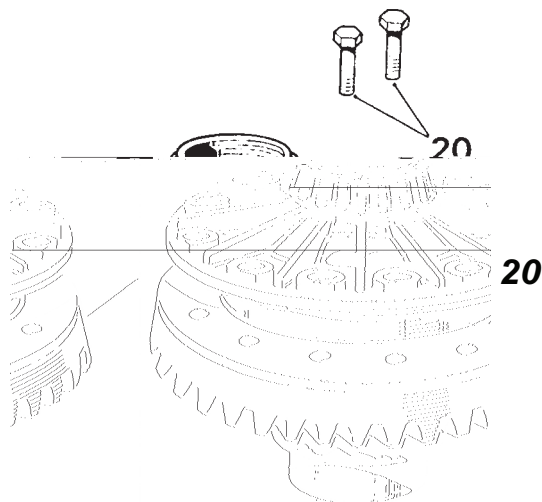

ST652M

21. Note the alignment markings on the two differential casings to ensure correct refitting, then remove the fixings.
22. Lift off the upper case.
23. Withdraw the upper differential wheel and thrust washer.

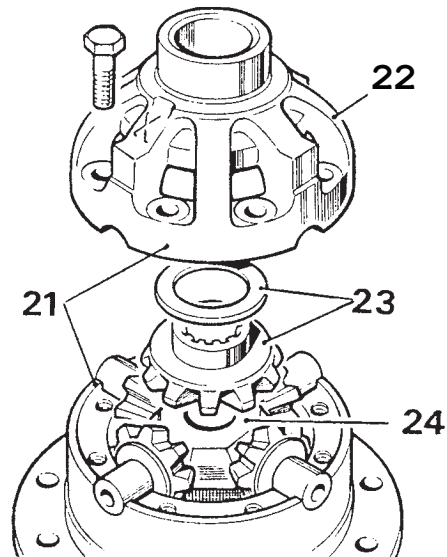

ST653M

24. Lift out the cross-shaft and pinions.
25. Withdraw the four dished thrust washers.
26. Withdraw the lower differential wheel and thrust washer.

continued

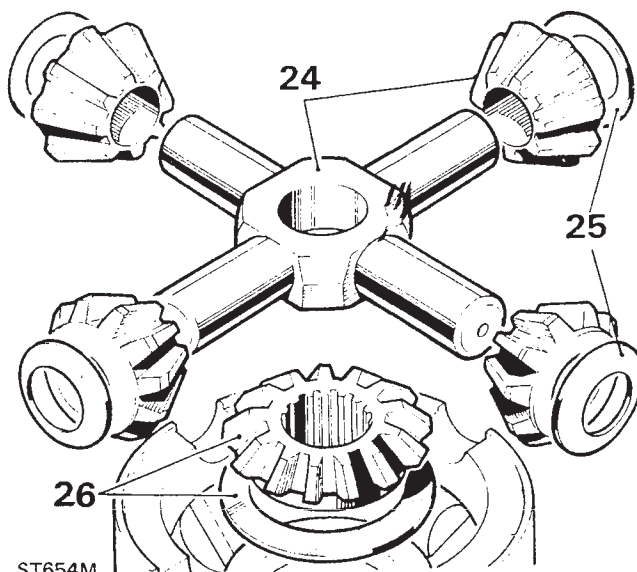

ST654M

27. Remove the differential bearing cones using remover 18G 47 BL and adaptors 1 and 2 and press 47.
28. Withdraw the shim washers fitted between the bearing cones and the differential casings.

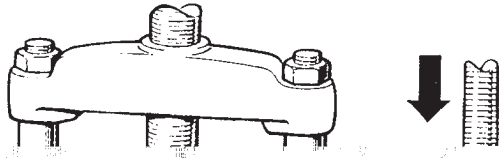

34. Withdraw the outer bearing cone.
35. Extract the pinion inner bearing cup and shim washers from the casing. Note the shim washer thickness. Remover S 123 A.
36. Extract the pinion outer bearing cup from the casing. Remover S 123 A.

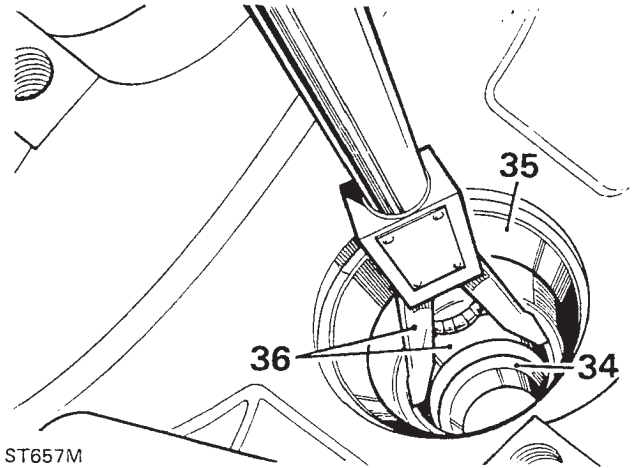

ST657M

37. Remove the inner bearing cone from the pinion. Remover 18G 47 RK and Press 47.

Remove final drive pinion

continued

29. Prevent the coupling flange from rotating and remove the flange locknut and plain washer. Spanner 18G 1205.
30. Support the drive pinion and remove the coupling flange by tapping with a hide hammer.
31. Withdraw the drive pinion together with the inner bearing cone.
32. Withdraw and discard the collapsible bearing spacer.
33. Withdraw the oil seal, gasket and oil thrower.

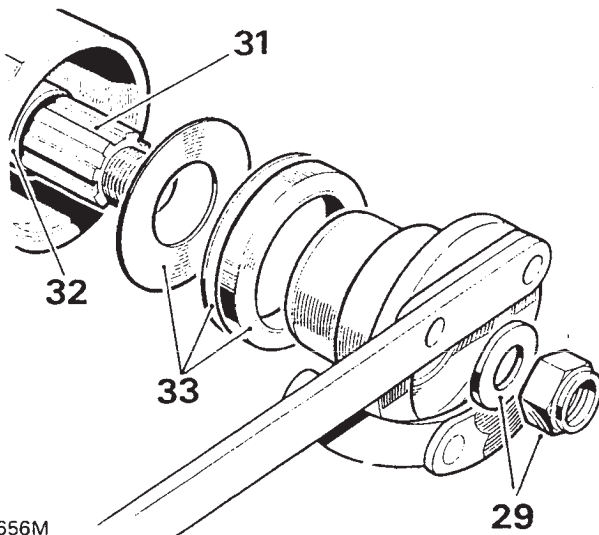

ST656M

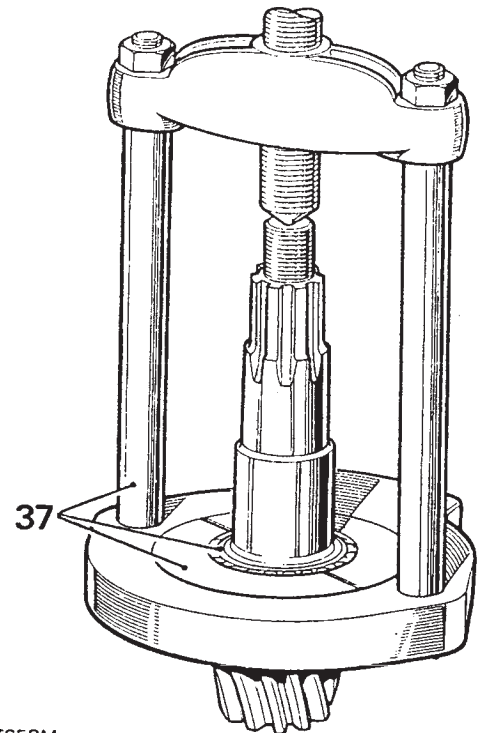

ST658M

INSPECTION

38. Examine all components for obvious wear or damage.
39. The bearing cones must be a press fit on their locations, except the drive pinion flange and bearing which is a slide fit.
40. The crown wheel and pinion are supplied as a matched pair and must not be interchanged separately.
A new crown wheel and pinion matched pair may be fitted to an original gear carrier casing if sound. The original crown wheel and pinion, if sound, may be fitted into a replacement casing.
41. The two parts of the differential unit casing are matched and must not be replaced separately.
42. Discard and renew all thrust washers.
43. Differential housings with worn thrust washer seatings must be replaced as a pair.
44. Examine the differential case to crown wheel joint face for burrs and damage which could lead to crown wheel run-out when fitted.

ASSEMBLE

Assemble differential unit

45. Fit the differential lower wheel and thrust washer to the differential case. See illustration following instruction 23.
46. Fit the dished thrust washers.
47. Fit the cross-shaft and pinions.
48. Fit the differential upper wheel and thrust washer.
49. Fit the differential upper case lining-up the marks.
50. Secure the assembly with bolts using Loctite 'Studlock' grade CVX on the threads and tighten evenly and diametrically to 9,1 to 10,4 kgf m (66 to 75 lbf ft).
51. Fit the crown wheel to the differential casing. Use Loctite 'Studlock' grade CVX on the fixing bolt threads and tighten to 13 to 14,5 kgf m (95 to 105 lbf ft).
52. Press on the differential roller bearing cones less shim washers, using 18G 134 DP, and leave to one side until required for instruction 96.
53. Fit the bearing cups to the differential.
54. Fit the differential unit and bearings to the gear carrier casing, and rotate unit to centralize the bearings. Do not fit the bearing caps.

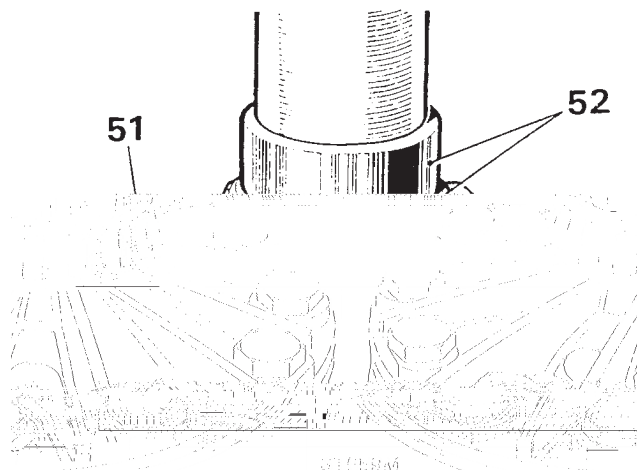

55. Position a suitable dial gauge indicator on the casing with the stylus registering on the back face of the crown wheel.
56. Rotate the differential and check the total indicated run-out on the crown wheel back face. This must not exceed 0,05 mm (0.002in). If run-out is excessive, check the mating faces for dirt and damage; if necessary, select a new radial position for the crown wheel. When satisfactory, continue with the following check.

Differential bearing adjustment

57. Insert two levers between the casing and the differential unit at one side.
58. Move the differential unit fully to one side of the casing; do not tilt the unit.
59. Rotate the differential unit to settle the bearings, continue to lever the differential to the side, then zero the dial gauge indicator.
60. Lever the assembly fully to the other side of the casing, rotate the unit to settle the bearings, then note the total indicator reading.

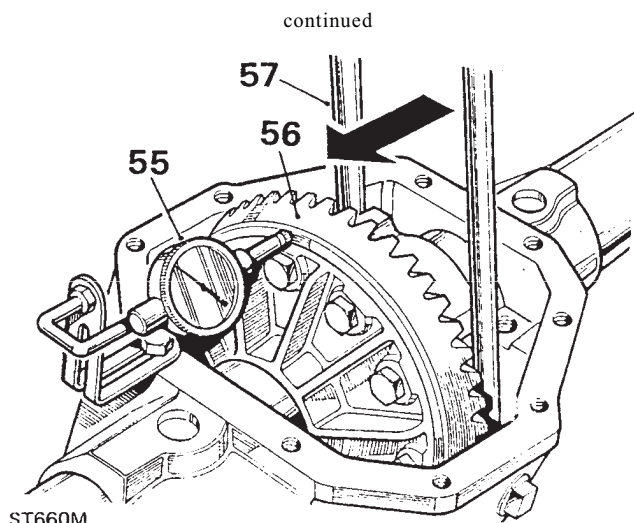

61. Add 0,127 mm (0.005 in), for bearing pre-load, to the total noted in the preceding instruction. The sum is then equal to the nominal value of shims required for the differential bearings:
Shims are available in the range 0,07 mm (0.003 in), 0,12 mm (0.005 in), 0,25 mm (0.010 in) and 0,76 mm (0.030 in). Select the total value of shims required.
62. Remove the differential unit and bearings and place aside. Do not fit the shim washers until the subsequent 'Differential backlash' checks have been made, instructions 96 to 102.

Fit drive pinion

63. Select shim washers of the same thickness value as those removed from under the pinion inner cup, instruction 35, and place ready for fitting.
64. Position the outer bearing replacer 18G 1122 G detail 2, and the outer bearing cup on the press tool 18G 1122.
65. Locate the assembly into the pinion housing nose.

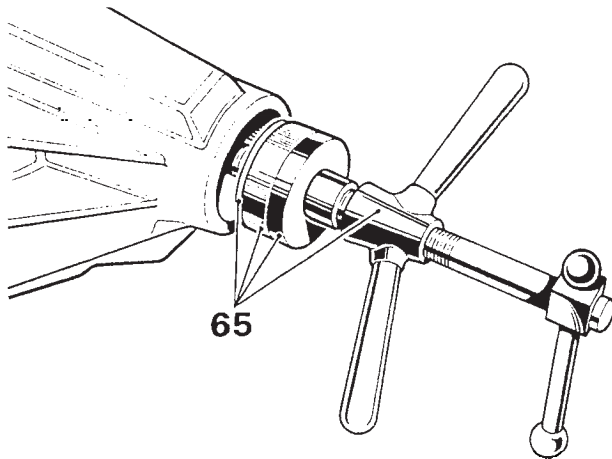

ST661M

66. Place the selected shim washers on to the inner bearing cup seating.
67. Position the inner bearing cup in the casing.
68. Position the inner bearing replacer 18G 1122 G detail 1, onto 18G 1122 and secure with the fixing nut.
69. Hold still the centre screw and turn the butterfly lever to draw in the bearing cups.

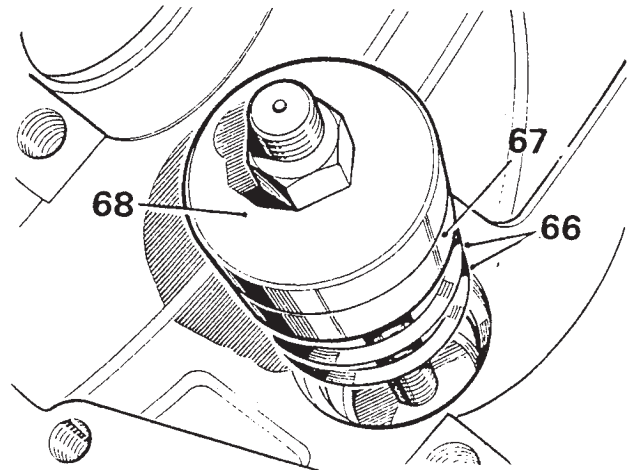

ST662M

70. Press the inner bearing cone onto the drive pinion. 18G 47 BK, details 1 and 2 and press 47.
71. Position the pinion and bearing in the casing; omit the collapsible spacer at this stage.
72. Fit the outer bearing cone onto the pinion.
73. Fit the coupling flange and plain washer and loosely fit the flange nut.
74. Tighten the coupling flange locknut to remove end-float from the pinion.
75. Rotate the pinion to settle the bearings and slowly tighten the flange locknut. Use a spring balance to obtain a torque resistance of 9,25 to 13,8 kgf cm (8 to 12 lbf in) to rotate the pinion.

continued

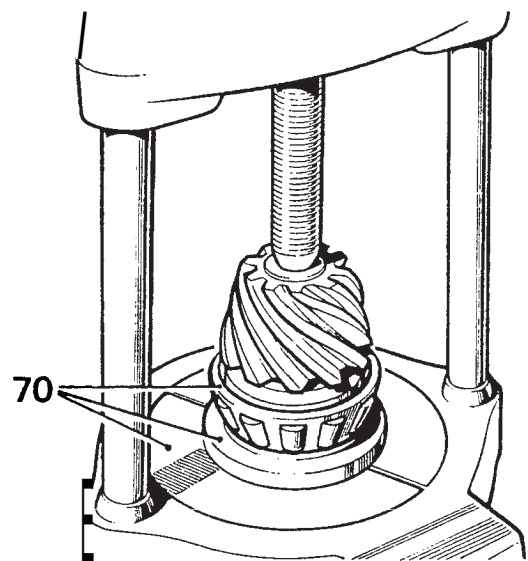

ST638M

Drive pinion markings

- 76. Check that the serial number marked on the pinion end face matches that marked on the crown wheel,
- 77. The markings on the end face adjacent to the serial number are of no significance during servicing.
- 78. The figure marked on the end face opposite to the serial number indicates, in thousandths of an inch, the deviation from nominal required to correctly set the pinion. A pinion marked plus (+) must be set below nominal, a minus (-) pinion must be set above nominal. An unmarked pinion must be set at nominal.

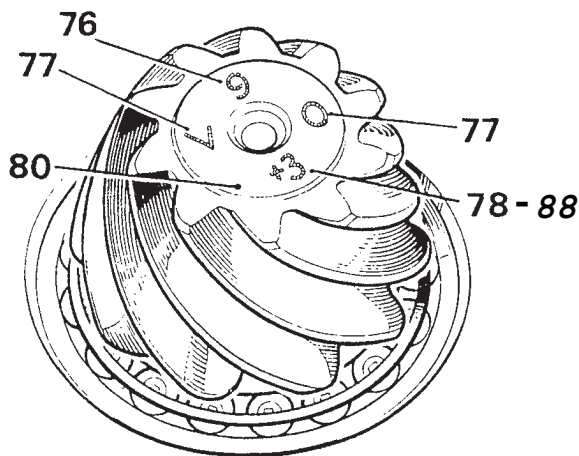

ST649M

- 79. The nominal setting dimension is represented by the setting gauge block 18G 191 P or 18G 191-4, which is referenced from the pinion end face to the bottom radius of the differential bearing bore. The latter gauge is illustrated following instruction 85.

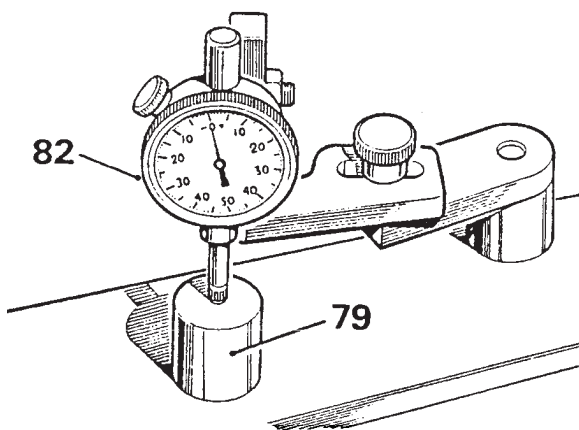

ST1380M

Drive pinion adjustment

- 80. Ensure that the pinion end face is free of raised burrs around the etched markings.
- 81. Remove the keep disc from the magnetized base of dial gauge tool 18G 191.
- 82. Place the dial gauge and setting gauge 18G 191 P or 18G 191-4 on a flat surface and zero the dial gauge stylus on to the setting gauge.
- 83. Position the dial gauge centrally on the pinion end face with the stylus registering on the lowest point on one differential bearing bore. Note the dial gauge deviation from the zeroed setting.
- 84. Repeat on the other bearing bore. Add together the readings, then halve the sum to obtain the mean reading. Note whether the stylus has moved up or down from the zeroed setting.

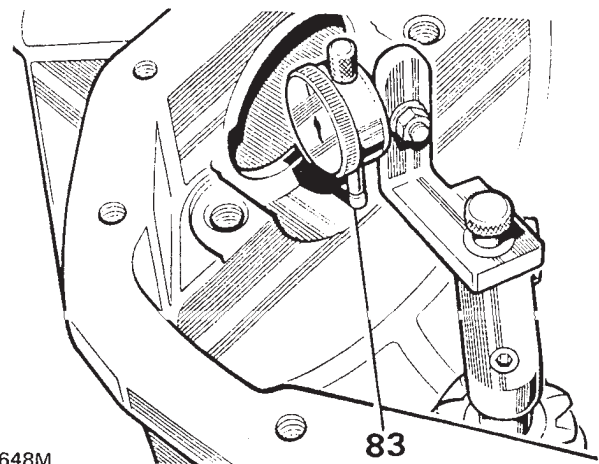

ST648M

Example 1

Reading obtained L.H. side + 0.006 in
 Reading obtained R.H. side - 0.003 in

$$\begin{aligned} &\text{Add } + 0.006 \text{ in} \\ &\quad - 0.003 \text{ in} \\ &= + 0.003 \text{ in} \\ &\text{Divide by 2} = \frac{+ 0.003}{2} = + 0.0015 \text{ in} \end{aligned}$$

Therefore **subtract** 0.0015 in from the shim thickness behind the pinion inner bearing track.

Example 2

Reading obtained L.H. side + 0.006 in
 Reading obtained R.H. side - 0.008 in

$$\begin{aligned} &\text{Add } + 0.006 \text{ in} \\ &\quad - 0.008 \text{ in} \\ &= - 0.002 \text{ in} \\ &\text{Divide by 2} = \frac{- 0.002}{2} = - 0.001 \text{ in} \end{aligned}$$

continued

- 85a. Where the stylus has moved down, the amount is equivalent to the thickness of shims that must be removed from under the pinion inner cup to bring the pinion down to the nominal position.
- b. Where the stylus has moved up, the amount is equivalent to the additional thickness of shims required to bring the pinion up to the nominal position.

Illustration A. Using setting gauge 18G 191 P.

Illustration B. Using universal setting block 18G 191-4

NOTE: The setting block has three setting heights as follows:
 39.50mm Rationalised axle
 38.10mm Pre-

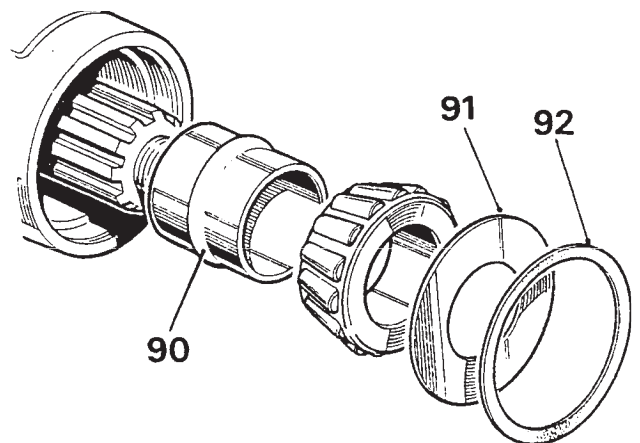
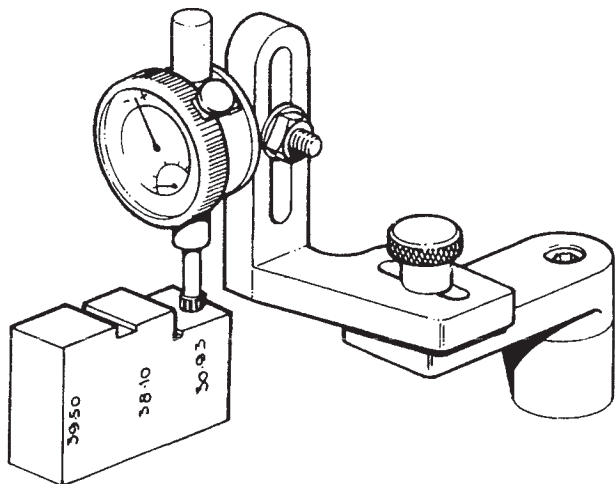
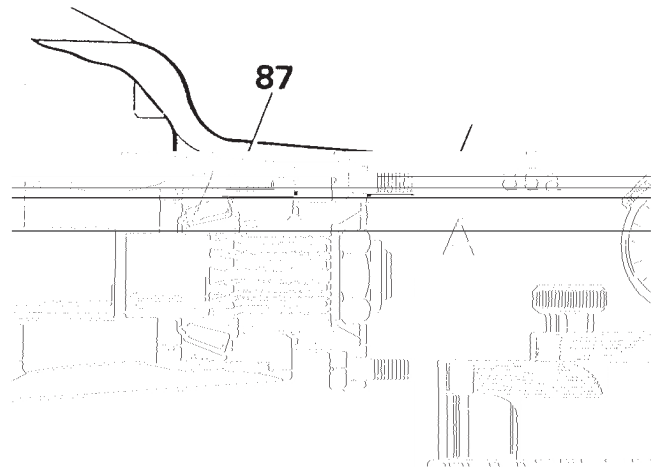
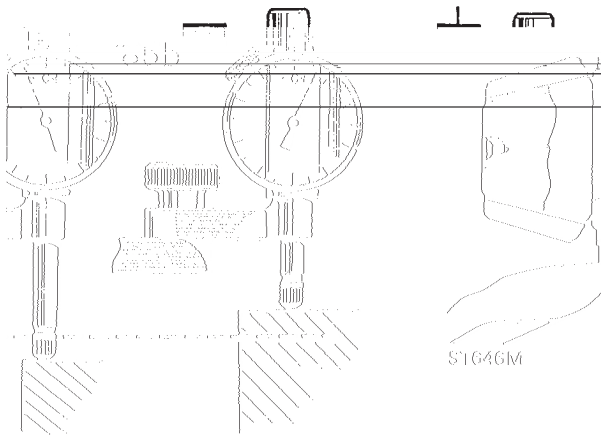

93. Fit the pinion oil seal, lipped side first, using general purpose grease or, where available, a molybdenum disulphide based grease on the seal lip, using RO 1008 to drift in the seal.
94. Fit the coupling flange and plain washer and loosely fit a new flange nut. Secure 18G 1205 to the coupling flange, using slave fixings.
95. Alternately tighten the flange nut and check the drive pinion resistance to rotation until the following figures are achieved, as applicable:
- a. Assemblies re-using original pinion bearings: 17,3 to 34,5 kgf cm (15 to 30 lbf in).
 - b. Assemblies with new pinion bearings: 34,5 to 46,0 kgf cm (30 to 40 lbf in).

NOTE: Once the bearing spacer has started to collapse the torque resistance build-

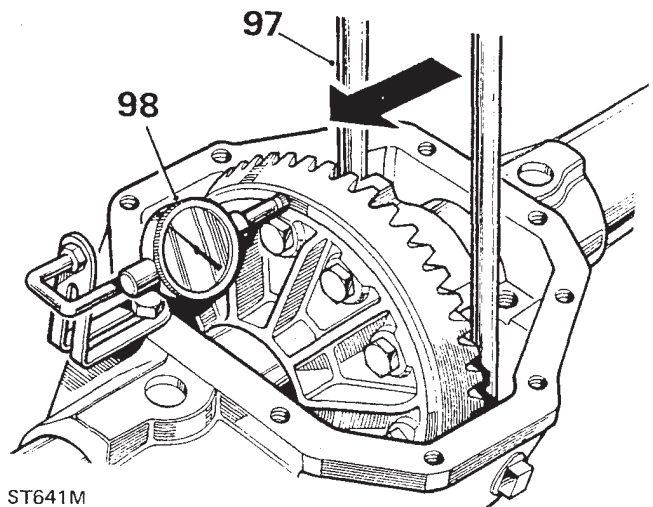

ST641M

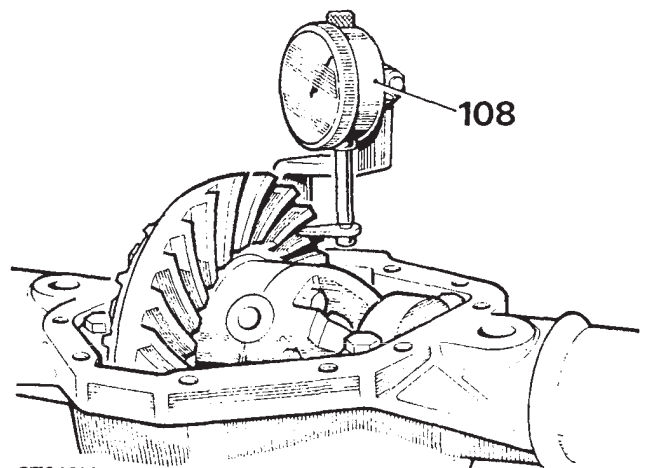
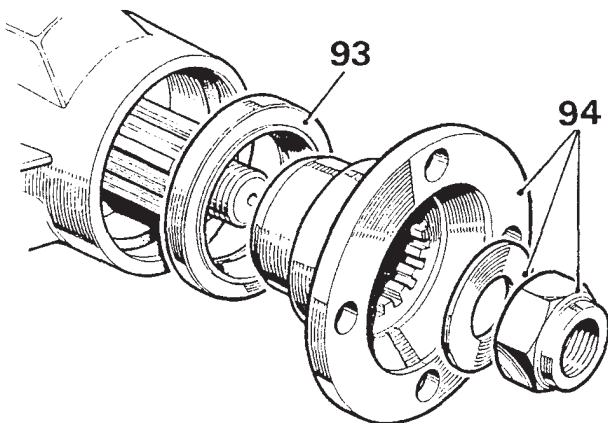

ST642M

- 109. Prevent the drive pinion from rotating and check the crown wheel backlash which must be 0,15 to 0,27 mm (0.006 to 0.011 in). If the backlash is not within the specified limits, repeat the differential backlash checks, instructions 96 to 102 looking for possible errors.
- 110. Fit the differential cover and new gasket, coating both sides of the gasket with Hylomar PL 32M or an equivalent non-setting sealant.
Torque load for fixings is 2,8 to 3,5 kgf m (20 to 25 lbf ft).
- 111. Reverse instructions 3 to 5 and coat the threads of the hub driving member bolts with Loctite 'Studlock' grade CVX and fit and tighten the bolts evenly. Torque: 10,0 kgf m (73 lbf ft).
- 112. Fit the rear axle assembly to the vehicle.
- 113. Replenish the differential lubricating oil, (see Lubrication chart). After the initial axle run, check the oil level and replenish as necessary to the filler/level plug hole.

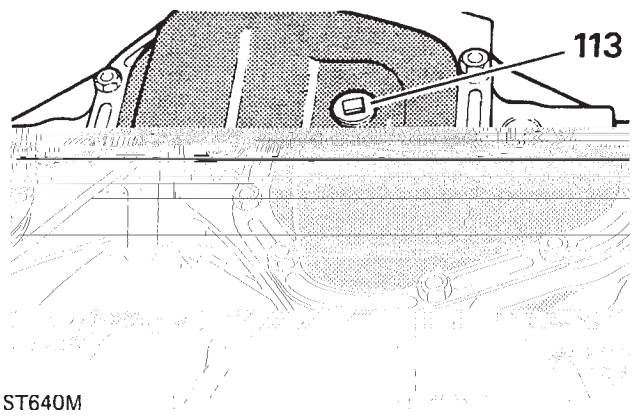

ST640M

- 114. Where major running parts have been replaced during servicing, it is a recommended practice to allow the axle assembly to 'run in' by avoiding, where possible, heavy loads and high speeds during initial running.

DATA

Crown wheel backlash	0,15 to 0,27 mm (0.006 to 0.011 in)
Differential bearings pre-load	0,127 mm (0.005 in)
Pinion height setting	Set using gauge 18G 191 P or 18G 191-4

Torque resistance initial setting figures

Torque to turn drive pinion and new pinion bearings ...	34,5 to 46 kgf cm (30 to 40 lbf in)
Torque to turn drive pinion re-using the original bearings .	17,3 to 34,5 kgf cm (15 to 30 lbf in)