

FOUR CYLINDER PETROL

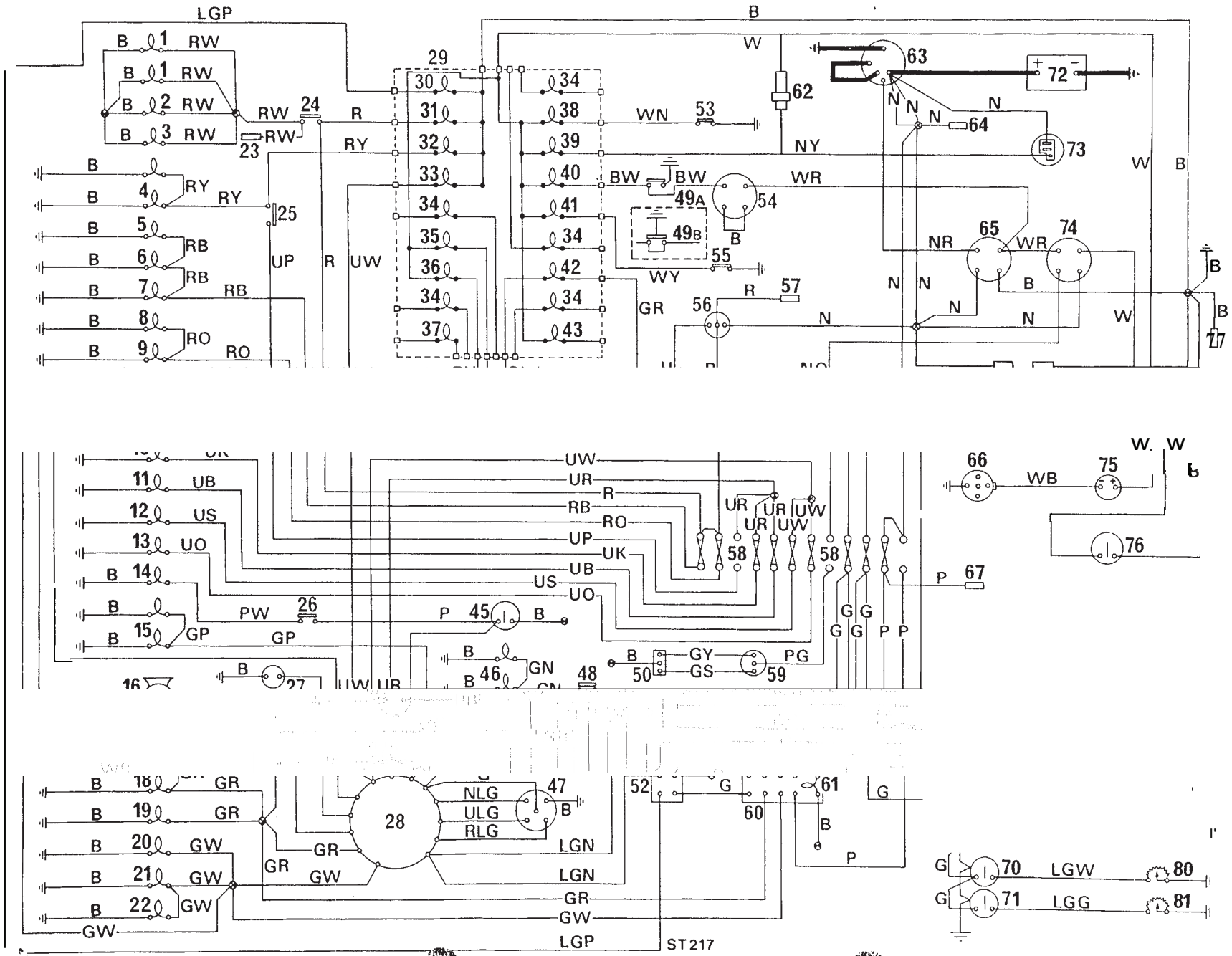

KEY TO FOUR CYLINDER PETROL DIAGRAM

- | | | |
|-------------------------------------------------------------------------------------------------------------------------------------------------------------------------------------------------------------------------------------------------------------------------------------------------------------------------------------------------------------------------------------------------------------------------------------------------------------------------------------------------------------------------------------------------------------------------------------------------------------------------------------------------------------------------------------------------------------------------------------------------------------------------------------------------------------------------------------------------------------------------------------------------------------------------------------------------------------------------------------------------------------------------------|--------------------------------------------------------------------------------------------------------------------------------------------------------------------------------------------------------------------------------------------------------------------------------------------------------------------------------------------------------------------------------------------------------------------------------------------------------------------------------------------------------------------------------------------------------------------------------------------------------------------------------------------------------------------------------------------------------------------------------------------------------------------------------------------------------------------------------------------------------------------------------------------------------------------------------------------------------------------------------------------------------|-----------------------------------------------------------------------------------------------------------------------------------------------------------------------------------------------------------------------------------------------------------------------------------------------------------------------------------------------------------------------------------------------------------------------------------------------------------------------------------------------------------------------------------------------------------------------------------------------------------------------------------------------------------------------------------------------------------------------------------------------------------------------------------------------------------------------------------------------------------------------------------------------------------------------------------------------------------------------------------------------------------------|
| <ol style="list-style-type: none"> 1. Speedometer illumination 2. Fuel indicator illumination 3. Water temperature illumination 4. Rear log lamps 5. Number plate lamp 6. LH tail lamp 7. LH side lamp 8. RH tail lamp 9. RH side lamp 10. LH headlamp dip beam 11. RH headlamp dip beam 12. LH headlamp main beam 13. RH headlamp main beam 14. Interior lamp 15. Stop lamp 16. Horn 17. LH side repeater 18. LH front indicator 19. LH rear indicator 20. RH front indicator 21. RH rear indicator 22. RH side repeater 23. Auxiliary instrument illumination 24. Panel illumination switch 25. Rear fog switch 26. Interior lighting switch 27. Washer pump 28. Steering column switches 29. Grouped warning lights (comprising items 30 to 43) | <ol style="list-style-type: none"> 30. Trailer warning light 31. Side light warning light 32. Rear fog warning light 33. Main beam warning light 34. Spare position 35. Low fuel warning light 36. Locked four-wheel drive warning light 37. Cold start warning light 38. Oil warning light 39. Charge warning light 40. Brake warning light 41. Park brake warning light 42. Direction indicator warning light 43. Seat belt warning light 44. Locked four-wheel drive switch 45. Clock 46. Reversing lamps 47. Wiper motor 48. Reversing lamp switch 49a Brake fluid loss switch (Ninety models only) 49b Pressure differential warning actuator switch (One Ten models only) 50. Heater switch 51. Stop lamp switch 52. Flasher unit 53. Oil pressure switch | <ol style="list-style-type: none"> 54. Brake check relay 55. Park brake switch 56. Light switch 57. Pick-up point for front fog lamps 58. Fuses 59. Heater motor 60. Hazard switch 61. Hazard switch illumination 62. Ignition light resistor 63. Starter solenoid 64. Spare pick-up point 65. Start relay 66. Distributor 67. Pick-up point for auxiliary trailer 68. Fuel indicator 69. Water temperature indicator 70. Oil pressure indicator 71. Oil temperature indicator 72. Battery 73. Alternator 74. Start switch 75. Coil 76. Battery condition indicator 77. Pick-up point for auxiliary instrument illumination 78. Fuel tank unit 79. Water temperature transmitter 80. Oil pressure transmitter 81. Oil temperature transmitter |
|-------------------------------------------------------------------------------------------------------------------------------------------------------------------------------------------------------------------------------------------------------------------------------------------------------------------------------------------------------------------------------------------------------------------------------------------------------------------------------------------------------------------------------------------------------------------------------------------------------------------------------------------------------------------------------------------------------------------------------------------------------------------------------------------------------------------------------------------------------------------------------------------------------------------------------------------------------------------------------------------------------------------------------|--------------------------------------------------------------------------------------------------------------------------------------------------------------------------------------------------------------------------------------------------------------------------------------------------------------------------------------------------------------------------------------------------------------------------------------------------------------------------------------------------------------------------------------------------------------------------------------------------------------------------------------------------------------------------------------------------------------------------------------------------------------------------------------------------------------------------------------------------------------------------------------------------------------------------------------------------------------------------------------------------------|-----------------------------------------------------------------------------------------------------------------------------------------------------------------------------------------------------------------------------------------------------------------------------------------------------------------------------------------------------------------------------------------------------------------------------------------------------------------------------------------------------------------------------------------------------------------------------------------------------------------------------------------------------------------------------------------------------------------------------------------------------------------------------------------------------------------------------------------------------------------------------------------------------------------------------------------------------------------------------------------------------------------|

Key to cable colours

B Black **G** Green **K** Pink **L** Light **N** Brown **O** Orange **P** Purple **R** Red **S** Slate **U** Blue **W** White **Y** Yellow

The last letter of a colour code denotes the tracer colour



Connectors via plug and socket



Snap connectors



Permanent in-line connections



Earth connections via cables



Earth connections via fixing bolts